

# PowerHold® Vehicle Restraint Specification Sheet and Submittal

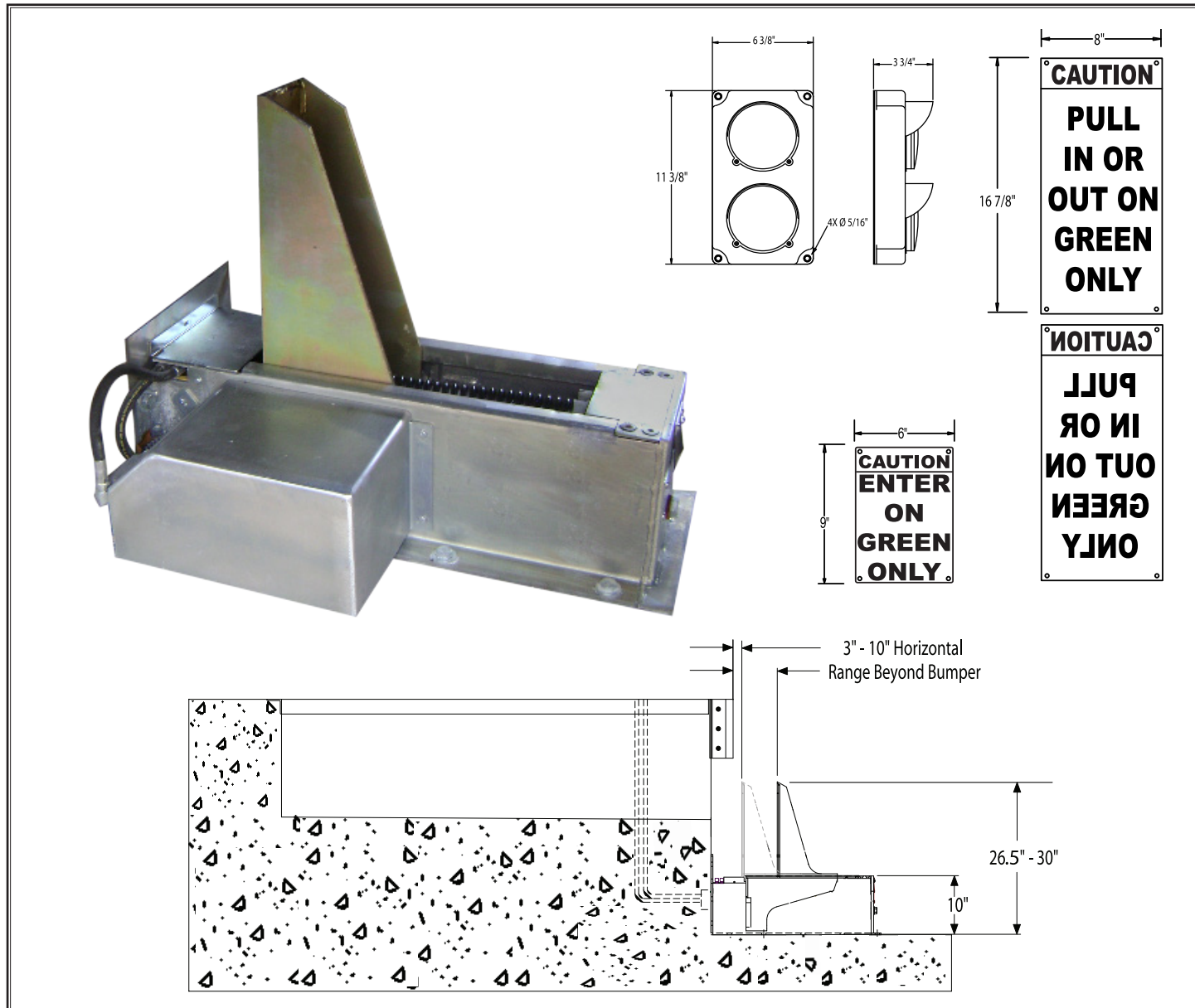

## STANDARD FEATURES FOR THE POWERHOLD® VEHICLE RESTRAINT

- Push Button Activation
- iDock™ Controls with Interactive Message Display
- Restraining Force In Excess of 32,000 lbs
- Non-Impact, Low Profile Design
- Corrosion Resistant Zinc Plated Finish
- Positive Restraining Force Eliminates “Trailer Creep”
- Auto Restore
- Custom PCV Solid State Control
- Amber Light - Caution Indicator
- Bypass/Override Passcode
- Dock Leveler or Door Interlock
- LED Interior and Exterior Lights
- Made in the USA



# PowerHold® Vehicle Restraint Specification Sheet and Submittal

**GENERAL DESCRIPTION:** All Poweramp® PowerHold® vehicle restraints are designed to secure a cargo trailer's rear impact guard (RIG) to reduce the likelihood of premature trailer separation during the loading/unloading process. The exclusive PowerHold vehicle restraint features a completely hydraulic restraint mechanism, inside iDock™ control panel, exterior communication lights and instructional signs.

**CONSTRUCTION:** The PowerHold restraint system is designed to be a stationary mount, non-impact device, permanently mounted to loading dock foundation or drive approach. Restraint back plate and housing shall be preserved in a zinc finish for all weather protection. Restraint arm shall be preserved in a highly visible zinc dicromate finish that is highly resistant to corrosion. Once activated, the PowerHold seeks a RIG and exerts positive pressure which virtually eliminates "trailer creep", securing the trailer with over 32,000 lbs. (average) of pull-out force.

**OPERATION:** As a trailer backs into position, the exterior light is green and the interior light is red. Once the trailer is positioned against the dock bumpers, the operator presses the "Engage" button. The interior light is amber and the exterior light is red while the restraint is in motion. An optional exterior strobe light indicator provides additional emphasis to driver during activation, pull-out and by-pass operation. The PowerHold rotates and seeks out the RIG. Once the trailer is secured the inside light will display green and the outside light will display red. The PowerHold provides a positive engagement for horizontal forces while the trailer is being loaded/unloaded. After the loading is complete, the operator presses the "Release" button. When the trailer is released and the restraint is safely stored the interior light changes to red while the exterior light changes to green.

If the PowerHold is unable to secure the trailer's RIG, the restraint automatically stores itself and an amber caution light as well as a message on the display appears. If "By-Pass" of the system is necessary, it is recommended that you secure the trailer by other means before proceeding with the loading/unloading process. In "By-Pass" mode the exterior light is red. The interior caution indicator light accompanies the green light indicating to the dock attendant that a caution situation is present. Manual reset of the "By-Pass" is accomplished by entering your bypass/override code.

**HYDRAULICS:** The PowerHold is a hydraulically actuated restraint with a programmable electronic controller and DockAlert™ communication system. The PowerHold vehicle restraint seeks, finds and maintains a tight, continuous hold on the RIG of truck throughout loading and unloading operations. It is programmed to control any gap between the restraint and the RIG, virtually eliminating "trailer creep". As an optional safety feature, the dock leveler and the vehicle restraint can be interlocked, preventing operation of the dock leveler until the restraint engages the RIG.

**HOOKING RANGE AND CAPACITY:** The PowerHold restraint system is designed to withstand a pulling force in excess of 32,000 lbs. on average, giving an added margin of safety and protection. Maximum operational range is 3" to 10" horizontally, from face of dock bumpers, and 10" minimum to 26½" maximum vertically. Extended ranges are available for certain applications.

**EXTERIOR LIGHTS:** Low profile, traffic style, red, and green lights are standard for communication to truck driver. A set of caution signs warns truck driver to "Back In or Pull Out On Green Light Only".

**ELECTRICAL:** The PowerHold vehicle restraint is available as a stand alone unit or combined electrically and hydraulically with your dock leveler selection. Hydraulic pump and motor is either ½ HP TENV at 120v or 208v single phase or 208v, 230v, 460v or 575v three phase. Electrical control panel is a NEMA 4X enclosure. All electrical control panel components, connections and wiring are UL listed/recognized.

**Please Note: Unless specifically noted on quotation, all electrical requirements, including mounting of control box, outside lights and signs, are the responsibility of others.**

**INSTALLATION:** Requires mounting of locking unit, control panel, exterior lights and signs in strict accordance with Poweramp installation instructions. Mechanical installation is recommended to be performed only by authorized Poweramp Representative.

**WARRANTY:** All PowerHold vehicle restraints feature a full two (2) year base warranty on all structural, hydraulic and electrical parts, including freight and labor charges in accordance with Systems, LLC's Standard Warranty Policy. Structural components carry an additional three (3) year extended warranty with parts and labor. Systems, LLC warrants all components to be free of defects in materials and workmanship, under normal use, during the warranty period. This base warranty period begins upon the completion of installation or the sixtieth (60th) day after shipment, whichever is earlier.

Integrated Control Panel Shown (Standard Size)



**Optional Equipment for PowerHold Vehicle Restraint**  
(Check options desired)

<input type="checkbox"/> Integrated Control Panel <small>(effects panel size)</small>	<input type="checkbox"/> Reduced Range _____
<input type="checkbox"/> Dock Leveler Interlock	<input type="checkbox"/> Increased Vertical Range to _____
<input type="checkbox"/> Limit Switch for Door Interlock	<input type="checkbox"/> Embed Plate ___ Wall ___ Drive
<input type="checkbox"/> Audible Alarm	<input type="checkbox"/> Anchor Pkg ___ Wall ___ Drive
<input type="checkbox"/> Dual Incoming Voltage	<input type="checkbox"/> CentraPower
<input type="checkbox"/> Self-Contained (110volt 1phase only)	<input type="checkbox"/> Other _____
<input type="checkbox"/> Combination Leveler/Restraint	<input type="checkbox"/> Other _____
<input type="checkbox"/> Remote Power Pack	<input type="checkbox"/> Other _____
<input type="checkbox"/> Cantilever Bracket _____ Projection	

\*Options must also be selected on the iDock Controls specification sheet

Customer: _____ Job: _____ Location: _____ Number of Units: _____ Voltage/Phase: _____ Represented By: _____ SalesRep: _____	<b>Certified For Construction:</b> By: _____ Date: _____ Company: _____ City & State: _____ Drawing #: _____
--	---

A continuing product improvement process is in effect at Systems, LLC. We reserve the right to make product changes without prior notice.

1/16/09/19 SS PH SS